



Electric Auto-Variable (EAV) fan



EAV Advantages

Compared to a Variable Speed Drive (VSD* - common flow regulation system), the Electric Auto-Variable fan (EAV) fan offers several benefits:



Installation benefits

No Need for a Dedicated Switchgear Room

- VSDs and their cabinets can be eliminated, avoiding the need for a switchgear room (SR).
- Additional energy savings are achieved by removing the need for SR air conditioning to cool VSDs

Simplified Motor Monitoring and Cabling

- No need to monitor electric motor temperature.
- Power, signal, and diagnostic cables from the SR to the DCS are no longer required.

Lower Maintenance Costs

- Fans operate most of the time at lower torque, significantly increasing lifespan and reducing maintenance requirements.

No Special Electric Motors or Cables Required

- Standard motors can be used without replacement.
- Shielded cables are unnecessary, and long cable runs (over 200m) are no longer a limitation.
- Avoids the need for sinusoidal filters, oversized VSDs, and associated efficiency losses.

Proven Pitch Control System

- Cofimco's pitch control system is installed in hundreds of plants, demonstrating high reliability and performance.

Quick and Easy Installation (New Equipment)

- Only simple low-power (50W VDC) plug-in signal and supply cables are needed.

Flexible Retrofit for Existing or Older Plants

- Ideal solution where:
 - The existing switchgear room has no available space.
 - No compressed air supply is available.
 - Power cable replacement is not feasible or too costly.

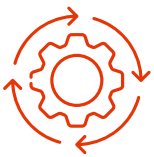

Operating benefits

No Fan Speed Skipping Required

- Fan resonance issues common with VSD systems are eliminated.
- The fan always operates at 100% design speed, avoiding critical vibration zones.
- No annoying whistle noise, often caused by VSDs at certain speeds.

Improved Regulation Stability at Low Airflow

- Full-speed operation ensures consistent aerodynamic performance, even at low airflow demands.
- Eliminates instability and wind effects typically encountered when motors run at reduced speed via VSDs.

Precise Blade Angle Control

- Blade pitch is continuously and accurately adjusted in response to control signals.
- Real-time feedback ensures exact blade positioning and high regulation accuracy.

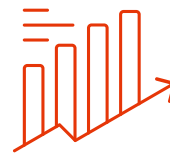

Economic benefits

Lower Initial Investment

- EAV systems are significantly more cost-effective to install than VSD-based setups.
- Savings apply across materials, installation labor, and site work.
- No need for specialized VSD engineering, programming, or commissioning expertise.

Reduced Power Costs and CO₂ Emissions

- EAV optimizes fan regulation to match cooling demand, eliminating energy waste.
- Only the power truly needed by the process is used, cutting energy costs and reducing environmental impact.

Faster Return on Investment (ROI)

- Thanks to lower upfront costs and year-round energy savings, EAV systems deliver a quicker payback compared to VSD solutions.

Perfect setting beyond the custom

The Electric Auto-Variable (EAV) fan, while using Cofimco standard FRP or Aluminum blades, has the peculiar feature to adjust the blades pitch angle to optimize the power consumption.

The pitch adjustment is carried out automatically and continuously while the fan is running. Therefore, a relevant energy saving can be achieved without stopping the fan and without hampering the cooling process.

The pitch can be set both in open or closed loop, to meet the cooling requirements at different air temperatures or process capacities. A continuous, very accurate blade pitch feedback is also provided, allowing an extremely accurate knowledge of the blade position.



The main architecture of the EAV fan

The EAV fan only needs a very simple electrical wiring circuit: for the actuator power supply and the control system, typically less than 50 W VDC are required. The EAV can be supplied for both ATEX or Safe Area applications. Suitable for ATEX environment:

- Group II, Category 2 G Ex h IIC T6...T4 Gb X
- Group II, Category 2 D Ex h IIIC T85°C...T135°C Db X



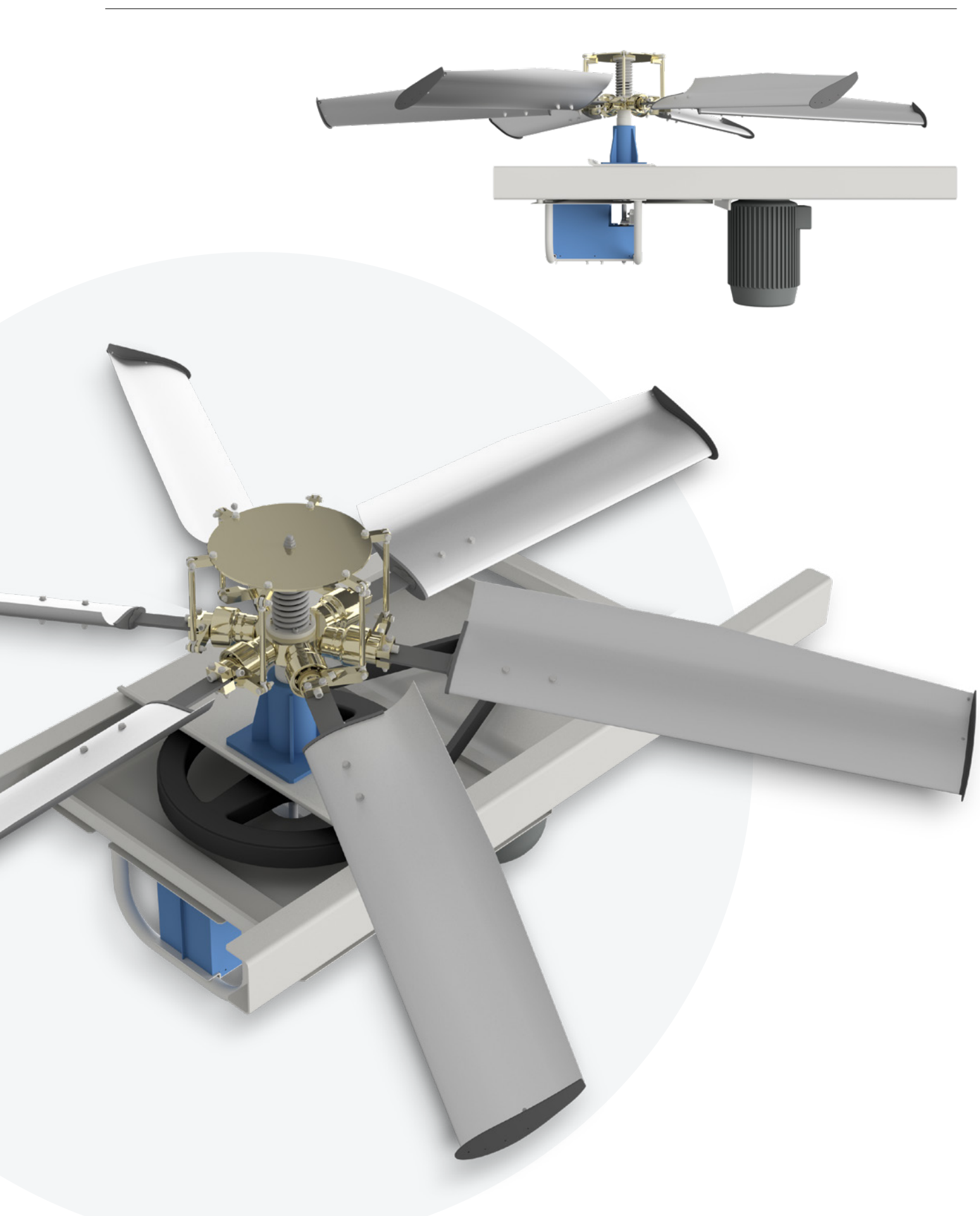

Cofimco's EAV reduces the blades pitch angle by 24° from the design duty point angle (*). Depending on the design pitch angle, the EAV standard configuration drops the flow rate according to the below table

Design Pitch	Reduced Pitch	Flow Rate	Power Consumption
18	/	100%	100%
18	-6	39.7%	6.2%
16	-8	34.7%	4.2%
14	-10	31.0%	3.0%
12	-12	25.9%	1.7%
10	-14	19.2%	0.7%

Note:

According to API 661, A.3.9, the design temperature is considered to be applied for a period of 400 hours/year. This means that, for at least 7600 h/y, a fixed-pitch fan works in incorrect conditions:

- It absorbs more power than necessary
- It provides more cooling than required causing critical issues to the industrial process control.

Consequently, the power consumption is dramatically reduced: down to 6.2% with a design pitch of 18° (see Fig. 1.2), down to 0.7% with a design pitch of 10°. Therefore, the EAV can provide an approximate energy saving in the range from 93% to 99%. The below figure brings the investment return shorter than one year.

(* Standard configuration - special design can be provided upon specific requirements.

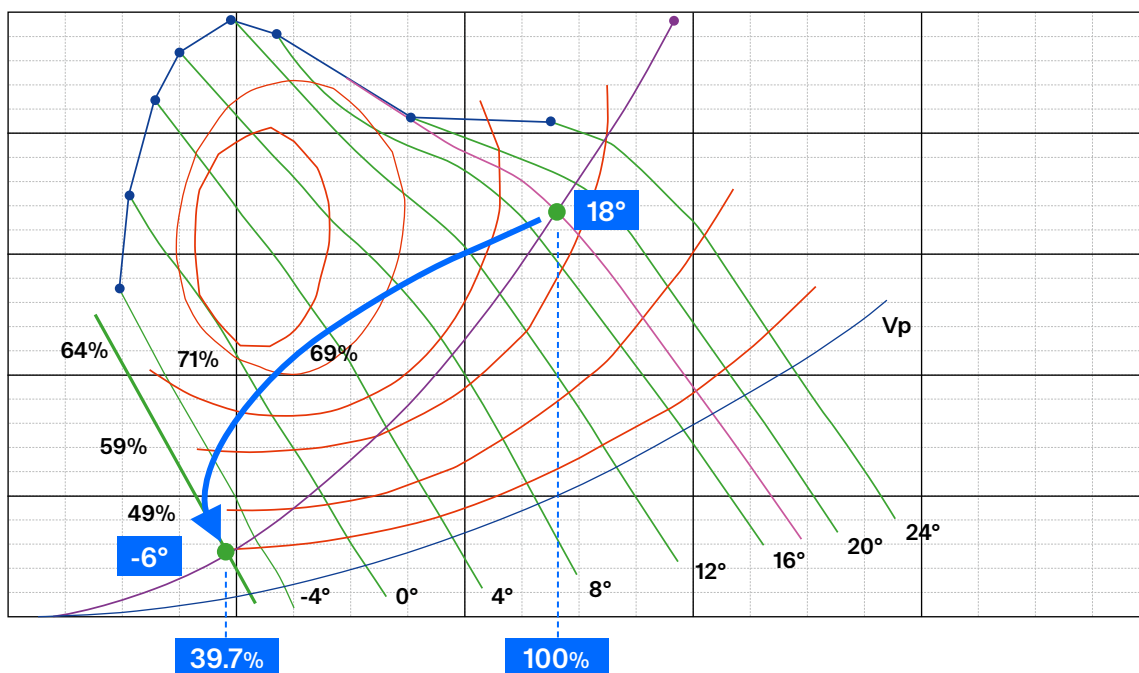

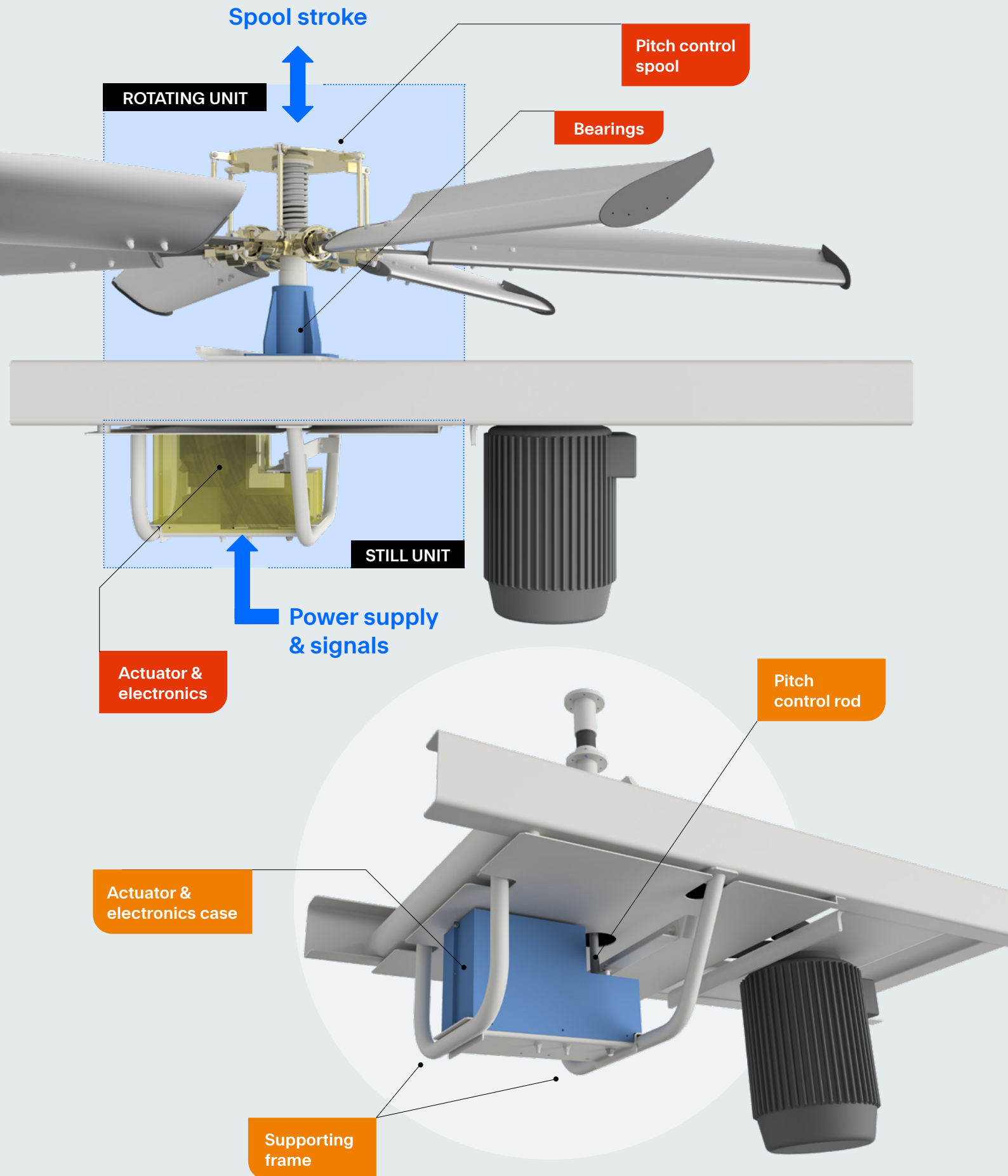

Cofimco – Five Decades of Excellence

For over 50 years, Cofimco has been a leader in axial fan technology for industrial applications. We provide **tailored solutions** to major global corporations, specializing in **large-scale projects** across the extractive and energy sectors.

Renowned for **quality, innovation, and manufacturing excellence**, Cofimco is the trusted partner for industry leaders, delivering **advanced cooling systems and high-performance airflow solutions** worldwide.



Cofimco S.p.A.

via A. Gramsci, 136
ITALY - 28050 POMBIA (NO)
Phone +39 0321 968311

Cofimco USA, LLC

184 White Road,
Houston, TX 77047
Phone +1 281-473-9010

info@cofimco.com
www.cofimco.com

cofimco[®]